



King Saud University
Saudi Pharmaceutical Journal

www.ksu.edu.sa
www.sciencedirect.com



REVIEW

Orally disintegrating films: A modern expansion in drug delivery system



Muhammad Irfan ^{a,*}, Sumeira Rabel ^a, Quratulain Bukhtar ^a,
Muhammad Imran Qadir ^b, Farhat Jabeen ^c, Ahmed Khan ^d

^a Department of Pharmaceutics, Faculty of Pharmaceutical Sciences, GC University, Faisalabad, Pakistan

^b Institute of Molecular Biology and Biotechnology, Bahauddin Zakariya University, Multan, Pakistan

^c Department of Zoology, Wildlife & Fisheries, GC University, Faisalabad, Pakistan

^d Department of Pharmacy, Quaid-i-Azam University, Islamabad, Pakistan

Received 30 January 2015; accepted 28 February 2015

Available online 10 March 2015

KEYWORDS

ODFs;
Novel drug delivery;
Formulation parameters;
Manufacturing techniques

Abstract Over the past few decades, tendency toward innovative drug delivery systems has majorly increased attempts to ensure efficacy, safety and patient acceptability. As discovery and development of new chemical agents is a complex, expensive and time consuming process, so recent trends are shifting toward designing and developing innovative drug delivery systems for existing drugs. Out of those, drug delivery system being very eminent among pediatrics and geriatrics is orally disintegrating films (ODFs). These fast disintegrating films have superiority over fast disintegrating tablets as the latter are associated with the risks of choking and friability. This drug delivery system has numerous advantages over conventional fast disintegrating tablets as they can be used for dysphasic and schizophrenic patients and are taken without water due to their ability to disintegrate within a few seconds releasing medication in mouth. Various approaches are employed for formulating ODFs and among which solvent casting and spraying methods are frequently used. Generally, hydrophilic polymers along with other excipients are used for preparing ODFs which allow films to disintegrate quickly releasing incorporated active pharmaceutical ingredient (API) within seconds. Orally disintegrating films have potential for business and market exploitation because of their myriad of benefits over orally disintegrating tablets. This present review attempts to focus on benefits, composition, approaches for formulation and evaluation of ODFs. Additionally, the market prospect of this innovative dosage form is also targeted.

© 2015 The Authors. Production and hosting by Elsevier B.V. on behalf of King Saud University. This is an open access article under the CC BY-NC-ND license (<http://creativecommons.org/licenses/by-nc-nd/4.0/>).

* Corresponding author. Tel.: +92 320 6504412.

E-mail address: manipharma@yahoo.co.uk (M. Irfan).

Peer review under responsibility of King Saud University.



Production and hosting by Elsevier

Contents

1. Introduction	538
2. Formulation	539
2.1. Active pharmaceutical ingredient	539
2.2. Hydrophilic polymers	539
2.3. Plasticizers	540
2.4. Surfactants	540
2.5. Flavor	540
2.6. Sweetening agents	540
2.7. Saliva stimulating agent	540
2.8. Coloring agents	540
3. Conventional approaches for manufacturing of orodispersible films	540
3.1. Solvent casting method	541
3.2. Semi-solid casting method	541
3.3. Hot melt extrusion	541
3.4. Solid dispersion extrusion	542
3.5. Rolling method	542
3.6. Spray technique	542
4. Characterization and evaluation	542
4.1. Organoleptic evaluation	542
4.2. Mechanical properties	543
4.2.1. Thickness test	543
4.2.2. Dryness test/tack test	543
4.2.3. Tensile strength	543
4.2.4. Percent elongation	543
4.2.5. Tear resistance	543
4.2.6. Young's modulus	543
4.2.7. Folding endurance	543
4.3. Swelling property	543
4.4. Transparency	543
4.5. Contact angle	544
4.6. Content uniformity	544
4.7. Disintegration time	544
4.7.1. Slide frame method	544
4.7.2. Petri dish method	544
4.8. In-vitro dissolution test	544
4.9. Visual inspection and surface morphology	544
4.10. Surface pH	544
4.11. Moisture uptake and moisture loss	544
5. Packaging of orally disintegrating films	544
6. Conclusion	545
References	545

1. Introduction

Oral route of drug administration is a most preferred route due to its ease of administration, non-invasiveness, adaptability, patient compliance and acceptability. Regarding oral route of drug administration, many substitutes have continuously been presented by using recent novel technologies for pediatrics, geriatrics, nauseous and non-compliance patients. Bioadhesive mucosal dosage forms including adhesive tablets, gels and patches are outcomes of technological development. Among various dosage forms, the use of polymeric films for delivering medication into buccal cavity has developed great potential in recent era (Arya et al., 2010). Orally disintegrating films (ODFs), when placed on tongue, immediately hydrates by soaking saliva following disintegration and/or dissolution

releasing active pharmaceutical agent from the dosage form (Chauhan et al., 2012). ODFs are kind of formulations which are commonly prepared using hydrophilic polymers enabling rapid dissolution upon contact with saliva. Oral disintegrating tablets (ODTs) and oral disintegrating films (ODFs) are the typical examples of orally disintegrating drug delivery systems. These systems were developed in late 1970 to serve as an alternative to conventional dosage forms, for instance, fast disintegrating tablets and capsules for geriatrics and pediatric patients having difficulty in swallowing conventional dosage forms (Liew et al., 2012). A typical ODF is usually equal to the size of a postage stamp. In market place, the introduction of ODT was strongly associated with counseling of patients about the appropriate administration by giving instruction like “do not chew/do not swallow”. However, in spite of these

instructions, incidents regarding chewing and swallowing were often reported. But, ODFs untied the masses from these adverse events. The administration of ODFs has numerous advantages and some of them are as follows:

- i. Easy transportation.
- ii. Ease of swallowing for geriatrics and pediatrics.
- iii. Convenient and accurate dosing.
- iv. No need of water for administration.
- v. Convenient for dysphasic patients having difficulty in swallowing tablets and capsules.
- vi. Rapid onset of action with increased bioavailability due to bypassing hepatic first pass effect and stability (Choudhary et al., 2012).

No expensive lyophilization, high mechanical strength, rapid disintegration, and reduced choking risks are the quality attributes of ODFs (Arya et al., 2010; Preis et al., 2012; Goel et al., 2008). ODFs have attained remarkable significance in pharmaceutical industry for the reason of possessing unique properties and fast disintegration time ranging from seconds to one minute (Choudhary et al., 2012). ODFs design permits to incorporate a variety of drugs for their pharmacological effects e.g., anti-tussive, anti-epileptic, anti-asthmatic, expectorant, etc. (Arya et al., 2010). High temperature and moisture sensitivity necessitating expensive packaging and inability of high dose loading are some disadvantages of ODFs.

2. Formulation

ODFs are fast disintegrating thin films having an area ranging from 5 to 20 cm² in which drug is incorporated in the form of matrix using hydrophilic polymer. Active pharmaceutical ingredient can be incorporated up to 15 mg along with other excipients i.e., plasticizers, colorants, sweeteners, taste masking agents, etc. Plasticizer increases workability, spreadability and flexibility of films thereby reducing the glass transition temperature of polymers. The general composition of an ODF is shown in Table 1 (Arya et al., 2010).

2.1. Active pharmaceutical ingredient

Various classes of drugs can be incorporated into ODFs e.g., anti-histamine, anti-diarrheal, anti-depressants, vasodilators, anti-asthmatic, anti-emetic, etc. (Chauhan et al., 2012). Dimenhydrinate can also be incorporated into ODFs for taste masking. Common examples of drugs incorporated into ODFs are salbutamol sulfate, rizatriptan benzoate, verapamil, ondansetron, dexamethasone, rofecoxib, cetirizine, pilocarpine, tianeptine sodium, indomethacin, etc. (Preis et al., 2012). An ODF of anti-emetic agent like prochlorperazine

Table 1 Composition of a typical ODF.

Components	Conc. (%)
Active pharmaceutical ingredient	1–25
Hydrophilic polymer	40–50
Plasticizer	0–20
Color, filler, flavor	0–40

was also formulated by employing microcrystalline cellulose and other film forming polymers (Nishimura et al., 2009).

2.2. Hydrophilic polymers

The successful development of an ODF is a function of justified selection and concentration of polymers as the mechanical strength of films is strongly associated with these factors. They can be used either alone or in combination with other polymers to modify film properties. The concentration of used polymers is also important factor while developing an ODF. The integrity of fast dissolving oral films is dependent upon careful selection of polymer nature and concentration. Generally, polymer concentration used in preparing ODFs is around 45% w/w of total weight of dry thin strip, however, it can be increased up to 60–65% w/w in order to attain the film of desired attributes and characteristics. Polymer used as a film forming agent in formulation of thin strips should possess certain properties (Table 2).

In recent era, both natural and artificial polymers are used for developing ODF formulation (Table 3) (Chauhan et al., 2012).

Different polymers are employed to modulate diverse properties of films. Pullulan has increased solubility next to the property of enhancing flexibility and films incorporating pullulan have high tensile strength and stability over a wide range of temperature. Molecular weights of gelatins affect the properties of prepared films and a significantly appealing film can be attained by using polymers with higher average molecular weight. The combination of chitosan and high methoxy pectin (HMP) or low methoxy pectin (LMP) provides excellent quality of strip. Cellulose derived film forming polymers viz hydroxypropyl methylcellulose (HPMC), hydroxypropyl cellulose (HPC), methyl cellulose (MC) and carboxymethyl cellulose (CMC) give films with less water vapor barrier due to their hydrophilic nature. Polyethylene glycol (PEG) also has

Table 2 Ideal properties of hydrophilic polymers.

Properties
Non-irritant
Should not hinder with the disintegration time of ODF
Affordable
Should possess adequate shelf-life
Should possess good spread ability
Should exhibit sufficient tensile strength
Should have good mechanical properties
Non-toxic
Non-irritant

Table 3 Most commonly used natural and synthetic polymers in ODFs.

Type of polymer	Examples
Natural	Starch, polymerized rosin, pullulan, sodium alginate, Pectin, gelatin, and maltodextrins
Synthetic	Polyvinyl alcohol, hydroxy propyl methyl cellulose, sodium carboxy methyl cellulose, polyvinyl pyrrolidone, and hydroxy propyl cellulose

a good film forming properties either alone or in combination with other polymers (Pathare et al., 2013).

HPMC is a very good film former and different grades viz Methocel E3, Methocel E5, Methocel E15 Premium LV, etc. are available. The development of fast dissolving film of triclosan prepared by using different grades of HPMC indicated that Methocel E15 Premium LV resulted into the films with appropriate properties (Dinge and Nagarsenker, 2008). Fast dissolving film of famotidine fabricated using HPMC and polyethylene glycol (PEG) depicted desired physico-chemical properties (Sonawane et al., 2012). A water insoluble drug (piroxicam) was incorporated into fast dissolving films prepared using maltodextrins (MDX) and equivalent low dose dextrose (Cilurzo et al., 2008). ODFs of neбиволол HCl prepared from HPMC, pullulan, polyvinyl pyrrolidone (PVP) illustrated that changing polymers concentration profoundly affects mechanical properties and percentage drug release (Parejiya et al., 2012). As polymers govern the release profile, mono- and double-layered buccoadhesive films of chlorhexidine were prepared to portray this fact. Films prepared with alginate and/or HPMC and/or chitosan controlled drug release in a better way (Juliano et al., 2008). ODFs of granisetron hydrochloride manufactured using pullulan and HPMC illustrated the effect of polymer concentration on mechanical properties and strength of film. Pullulan with 40–45% concentration did not yield films with good properties whereas HPMC up to 40% amount resulted into films which were difficult to peel. Furthermore, the stickiness of film increased when the concentration of HPMC was above 50% (Chaudhary et al., 2013). A study of preparing fast dissolving films of losartan potassium applying different concentrations of maltodextrin (MD) and polyvinyl alcohol (PVA) demonstrated that in vitro disintegration time varied directly as a function of increased polymer concentration (Bansal et al., 2013). Another study revealed that pullulan serves as a best film forming agent among all investigated polymers (Kulkarni et al., 2010). Fast dissolving films of cetirizine using 2% w/v pullulan were thin and brittle, thus, slightly higher concentration was used (Mishra and Amin, 2011). Affectivity of ODFs might be judged by comparing the pharmacokinetic properties (blood profile) of the reference (oral solution of pure drug) and the sample film of levocetirizine containing pullulan by testing on Sprague–Dawley rats (Choudhary et al., 2012).

2.3. Plasticizers

In general, mechanical properties such as tensile strength and percent elongation are improved by adding plasticizer to the formulations (Arya et al., 2010). The concentration of plasticizer usually ranges from 0% to 20% w/w. Common examples of plasticizers are PEG, glycerol, diethyl phthalate, triethyl citrate, tributyl citrate, etc. (Bala et al., 2013).

2.4. Surfactants

Surfactants play a vital role as dispersing, wetting and solubilizing agent thus enabling films to disintegrate within seconds releasing the incorporated drug, speedily. Commonly used surfactants are benzalkonium chloride, tweens, and sodium lauryl sulfate. Often, polaxamer 407 is used due to its many advantages (Siddiqui et al., 2011).

2.5. Flavor

Flavors are needed to mask the bitter or nauseating taste of incorporated drug. Amount of flavor depends upon its nature and strength. Any US-FDA approved flavor can be used such as sweet, sour or mint flavor (Siddiqui et al., 2011). One of the research work verified that mint, licorice and sucralose mixture flavors appropriately mask the bitter taste of diclofenac sodium. Electronic tongues are used to discriminate the effect of various taste masking agents (TMAs) (Cilurzo et al., 2011).

2.6. Sweetening agents

Sweetening agents are designed to disintegrate or dissolve in oral cavity. Both artificial and natural sweeteners are used in preparing ODFs (Table 4).

Neotame and Alitame are 2000–8000 times sweeter than sucrose (Siddiqui et al., 2011). Fructose has more sweetening power compared to sorbitol and mannitol (Desu et al., 2013). Sucralose was found to be 600–1000 times sweeter than sucrose when oral disintegrating films of donepezil were evaluated for taste, after taste mouth feel. Aspartame and saccharin sodium are likely to be 200 and 300–500 times sweeter compared to sucrose, respectively. It was also reported that sweeteners and flavors have minor effect on flexibility of film (Liew et al., 2012).

2.7. Saliva stimulating agent

Salivary stimulants are generally acidic in nature stimulating the production of saliva in buccal cavity, consequently, promoting the disintegrating of ODFs. Some commonly used saliva stimulating agents are citric acid, malic acid, tartaric acid, ascorbic acid and lactic acid (Siddiqui et al., 2011).

2.8. Coloring agents

Pigments are used as coloring agents. Titanium dioxide is most widely used colorant in ODFs and various other pharmaceutical preparations. Apart from titanium dioxide, a full range of colors are available including FD and C, natural and custom pantone-matched colors (Siddiqui et al., 2011).

3. Conventional approaches for manufacturing of orodispersible films

Methods mainly employed for manufacturing ODFs are shown in Fig. 1 (Siddiqui et al., 2011).

Table 4 Examples of some commonly used sweetening agents in ODFs.

Sweetening agent	Example
Natural	Glucose, fructose, dextrose, sucrose, and isomaltose
Artificial	Acesulfame-K, sucralose, and neotame

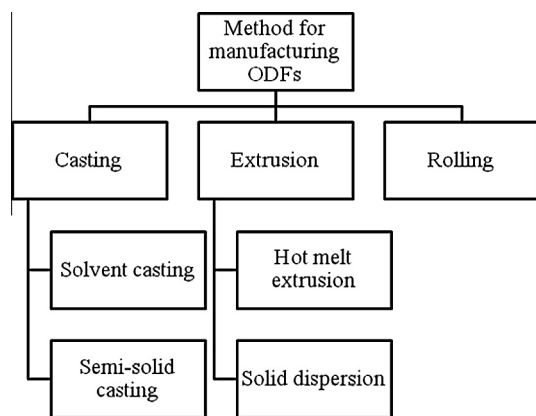

Figure 1 Conventional approaches for manufacturing ODFs.

3.1. Solvent casting method

Solvent casting is the most commonly used method for the preparation of ODFs using water soluble excipients, polymers and drug which are dissolved in de-ionized water; consequently, a homogenous mixture is obtained by applying high shear forces generated by a shear processor. Then, the prepared solution is poured onto petri plate and the solvent is allowed to dry by exposing it to high temperature in order to attain good quality films (Fig. 2) (Choudhary et al., 2012; Thakur et al., 2012).

An orodispersible film of tianeptine sodium was successfully prepared through solvent casting technique using different grades of Lycoat and HPMC (El-Setouhy and El-Malak, 2010). In solvent casting technique, film forming polymer is

usually soaked in an appropriate solvent for overnight. The type of API, which has to be incorporated in ODF, governs the selection of a suitable solvent depending on critical physico-chemical properties of API such as melting point, shear sensitivity and polymorphic form. Compatibility of drug with solvent and other excipients is also brought under consideration before finalizing a formulation. During formulation, entrapment of air bubbles can hinder the uniformity of prepared films. Thus, deaeration of the mixture is carried out with the help of a vacuum pump (Fig. 3) (Panda et al., 2012).

Orodispersible film formulation of mosapride was also successfully prepared by using solvent casting method (ElMeshad and Hagrasy, 2011). Viscosity of the solution to be poured is an imperative aspect in casting method. The concentration of pullulan varying from 2% to 8% results into low viscosity solution, as a result, enabling easy casting of films (Murata et al., 2010). Fast disintegrating films of anastrozole were also effectively prepared with the help of solvent casting method employing HPMC (E5) and polyvinyl alcohol (PVA) (Satyanarayana and Keshavarao, 2012).

3.2. Semi-solid casting method

Flow map of semi-solid casting method is given below in Fig. 4 (Thakur et al., 2012).

3.3. Hot melt extrusion

Hot melt extrusion is a technique in which a mixture containing drug, polymer and excipients is extruded under high

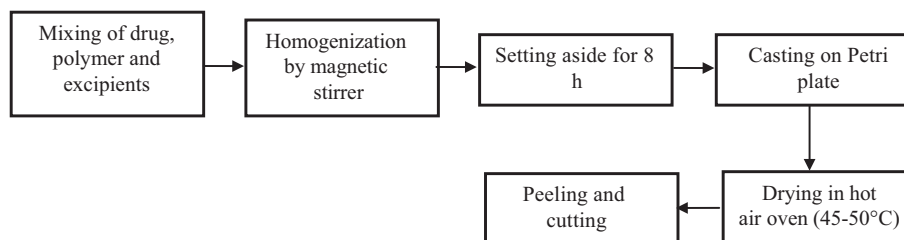

Figure 2 Flow chart of solvent casting method.

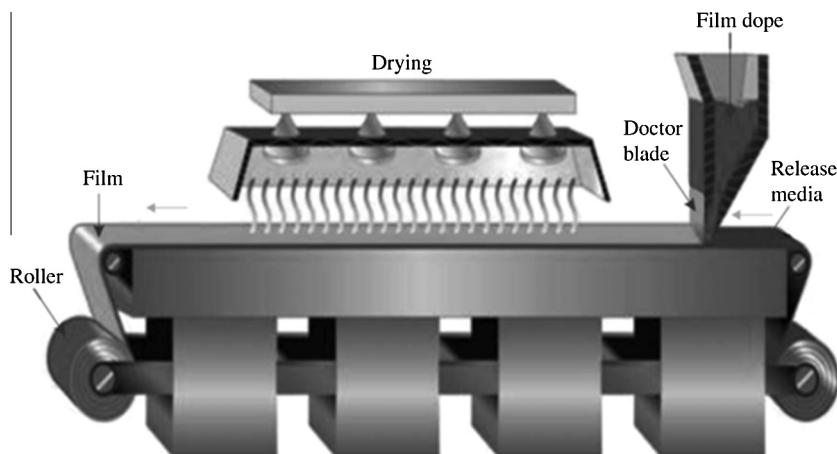

Figure 3 Description of solvent casting technique.

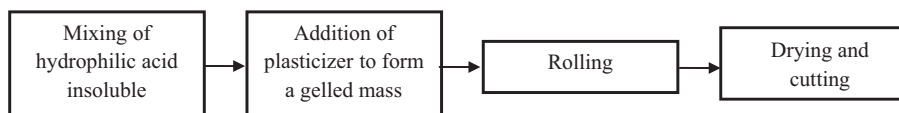

Figure 4 Flow map of semi-solid casting method.

temperature to form a homogenous mass which is then casted to form smooth films. This is a solvent free process, however, the processing of thermolabile substances is a major drawback of this process due to the use of high temperature during extrusion (Fig. 5) (Thakur et al., 2012; Panda et al., 2012).

3.4. Solid dispersion extrusion

Solid dispersion of domperidone using beta-cyclodextrin, PEG 400 and HPMC E15 was successfully prepared and films were casted using solid dispersion extrusion method (Fig. 6) (Thakur et al., 2012; Joshi et al., 2012).

3.5. Rolling method

Plot of rolling method is shown in Fig. 7 (Thakur et al., 2012).

The prepared solution should possess specific rheological properties for rolling onto the drum (Panda et al., 2012).

3.6. Spray technique

Drug substance, polymers and all other excipients are dissolved in a suitable solvent to form a clear solution. This clear solution is then sprayed onto suitable material such as glass, polyethylene film of non-siliconized Kraft paper or Teflon sheet (Fig. 8) (Panda et al., 2012).

4. Characterization and evaluation

Characterization of films is accomplished via following tests:

4.1. Organoleptic evaluation

Special controlled human taste panels are used for such purpose. This in vivo taste evaluation is carried out on human volunteers. In-vitro taste evaluation of ODFs is performed by using taste sensors for screening. In vitro taste assessing

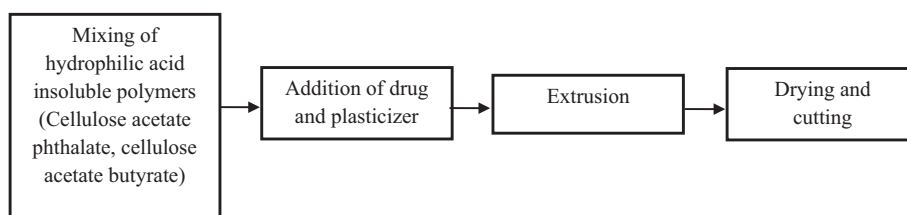

Figure 5 Flow chart of hot melt extrusion method.



Figure 6 Flow map of solid dispersion method.

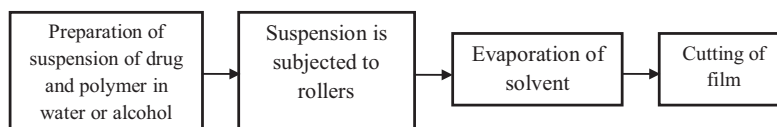

Figure 7 Plot of rolling method.

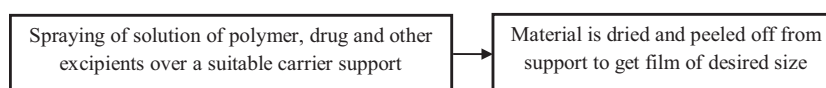

Figure 8 Manufacturing of ODFs by spray method.

methods and technologies are appropriate and sufficient for high-throughput taste sensing of such dosage forms. Both in vivo and in vitro techniques analyze the taste masking ability and sweetness level of taste masking agents.

4.2. Mechanical properties

4.2.1. Thickness test

Thickness of a film is determined by using calibrated digital micrometer and then subsequently mean average is calculated. Generally, three readings from all the batches are determined and average is calculated. Weight variation of a film is calculated in triplicate by cutting the film and determining weight of each film. Uniformity in thickness is important to ascertain as it is directly proportional to dose accuracy of the film.

4.2.2. Dryness test/tack test

This test is performed to find out the ability of a film to get adhered to a piece of paper pressed between strips (Chaudhary et al., 2013). Obstinance with which the film adheres with the piece of paper or any other accessory pressed in between the films is known as tack. Almost there are eight stages of film drying process which are identified viz dry-to touch, dry-to-recoat, dry hard, set-to-touch, dust-free, dry-through, tack-free and dry print-free. Primarily these tests are used to evaluate dryness of films in paint industry but are also adoptable for assessing orally fast disintegrating films. Dryness or tack test can also be performed by with the help of some newly invented instruments (Bhyan et al., 2011).

4.2.3. Tensile strength

Tensile strength is defined as maximum stress applied at which the film breaks. Basically, this test is performed to measure the mechanical strength of films. It can be calculated from applied load at rupture divided by the strip cross-sectional area given in the equation below:

$$\text{Tensile strength} = (\text{load at failure}/\text{strip thickness} \\ \times \text{strip width}) \times 100$$

4.2.4. Percent elongation

Upon exerting stress on a film, the specimen stretches which is referred as strain. Strain is defined as change in length of film divided by its original/initial length of the film specimen. Percent elongation is related quantitatively to the amount of plasticizer used in film formulation. Increased plasticizer concentration in the film generally results in enhanced elongation of the strip. It is determined by the following formula:

$$\text{Percentage elongation} = (\text{change in length}/\text{initial length}) \\ \times 100$$

4.2.5. Tear resistance

Tear resistance of film is the intricate function of its ultimate resistance to rupture. Maximum force required to tear the film is measured as tear resistance value. This test is typically attributed to plastic industry. The rate of loading employed is 2 in/min which is planned to determine the magnitude of force required to initiate tearing in the film specimen. The maximum

amount of force necessary for tearing is generally found near the tearing onset which is ranked as tear resistance value (Bhyan et al., 2011).

4.2.6. Young's modulus

It is the measure of film stiffness. It is found as ratio of applied stress to the strain in the elastic deformation region. It is determined by the following formula:

$$\text{Young's modulus} = (\text{slope}/\text{strip thickness} \\ \times \text{cross head speed}) \times 100$$

It can also be written as:

$$\text{Young's modulus} = \text{force at corresponding} \\ \text{strain}/\text{cross-sectional area} \\ \times \text{corresponding strain}$$

Hardness and brittleness are characteristics of the films which are related with Young's modulus and tensile strength. A hard and brittle film depicts higher value of tensile strength and Young's modulus with small elongation (Bhyan et al., 2011).

4.2.7. Folding endurance

Folding endurance is another procedure to estimate the mechanical properties of a film. It is measured by repeatedly folding a film at the same point until it breaks. Folding endurance value is number of times the film is folded without breaking. Higher folding endurance value depicts the more mechanical strength of a film. A direct relation exists between mechanical strength and folding endurance of films. As mechanical strength is governed by plasticizer concentration so it is clearly evident that plasticizer concentration also indirectly affects folding endurance value.

4.3. Swelling property

Simulated saliva solution is used to check the swelling studies of films. Initial weight of film is determined and is placed in pre-weighed stainless steel wire mesh. This mesh containing film is then dipped into simulated saliva solution. Increase in the weight of film is noted at constant pre-determined time intervals until no more increase in weight. Degree of swelling is determined by these parameters:

$$\text{Degree of swelling} = \text{final weight} (w_t) \\ - \text{initial weight} (w_0)/\text{initial weight} (w_0)$$

w_t = weight of film at time interval t ; w_0 = weight of film at time 0.

4.4. Transparency

Transparency of a strip is determined by using a UV-spectrophotometer. This test is performed for visual appearance of the formulation. Film specimen are cut into rectangular shapes and placed on the internal side of the photometer cell. Transmittance of the film is worked out at 600 nm wavelength. Formula for determining transparency is given as:

$$\text{Transparency} = (\log T600)/b = -\epsilon c$$

T_{600} = transmittance at 600 nm, b = film thickness (mm), and c = concentration.

4.5. Contact angle

Contact angle of a film is usually measured at room temperature with the help of a device known as goniometer. On the dry film surface, a drop of double distilled water is placed. Water droplet images are recorded within 10 s after the placement of drop with the help of a digital camera. These digital pictures are analyzed by using image 1.28 V software for determining contact angle. Contact angle is measured on both sides of droplets and mean is calculated. Contact angle is determined at least five times at different positions to have a clear idea about the nature of films.

4.6. Content uniformity

Contents of a film are determined by standard assay method specified for individual drug in different pharmacopoeia. This test is performed on 20 samples using analytical techniques. The acceptance value of the test is less than 15% in accordance with Japanese pharmacopoeia. According to USP27, the contents should range from 85% to 115% with the standard deviation of less than or equal to 6% (Chaudhary et al., 2013). Content uniformity is worked out for estimating drug contents in individual film (Bhyan et al., 2011).

4.7. Disintegration time

Disintegration apparatus mentioned in official pharmacopoeias is used for determining the disintegration time of a film. Normally, the disintegration time is the function of composition of film as it varies with the formulation and generally ranges from 5 to 30 s. Mostly, the USP disintegration apparatus is used for this test. There are no official guidelines available for determining disintegration time of orally fast disintegrating films (Bhyan et al., 2011). There are two methods for determining disintegration time of film:

4.7.1. Slide frame method

A drop of distilled water is poured onto the film clamped into slide frames placed on petri dish. Time taken by the film to dissolve is noted.

4.7.2. Petri dish method

A film is placed onto 2 ml distilled water taken in petri dish. Time taken by the film to dissolve completely is considered as the disintegrating time (Patil et al., 2014).

4.8. In-vitro dissolution test

Standard official basket or paddle apparatus is used for conducting dissolution studies on films. Sink conditions should be maintained during dissolution. Sometimes while performing this process, film floats over the medium making it difficult to perform the test properly. This problem is more likely to occur in case of paddle method thus the basket apparatus

is mostly preferred. Media used are 6.8 pH phosphate buffer (300 ml) and 0.1 N HCl (900 ml). Temperature is maintained at 37 ± 0.5 °C and rotation speed of 50 rpm is usually adjusted. Samples of drug dissolved are collected at pre-determined intervals and are analyzed by using UV-spectrophotometer. Despite its extensive use, dissolution test is still prone to noteworthy inaccuracy and tests letdown (Bai et al., 2007).

4.9. Visual inspection and surface morphology

Visual inspection of a prepared orodispersible film gives information about color, homogeneity and transparency (Raju et al., 2011). For surface morphology, scanning electron microscopy is performed. Absence of pores and surface uniformity depicts good quality of films.

4.10. Surface pH

The pH value of a film is usually determined by putting the prepared film in petri dish and subsequently film is made wet by using distilled water and noting pH by touching the film surface with a pH meter electrode. Determination of surface pH is vital as acidic or basic pH is liable to cause oral mucosal irritation (Patel and Poddar, 2009).

4.11. Moisture uptake and moisture loss

Percent moisture loss is a parameter that determines the hygroscopicity of a film. Usually, this parameter is determined by first finding the initial weight of the film, afterward, putting this film in a desiccator for three days. Desiccator contains calcium carbonate. After three days, strips are taken out and weighed again. Moisture loss is determined by applying the following formula (Yellanki et al., 2011).

$$\begin{aligned} \text{Percentage moisture loss} &= \text{initial weight} \\ &\quad - \text{final weight}/\text{initial weight} \\ &\quad \times 100 \end{aligned}$$

Moisture uptake of a film is determined by first cutting the film with the dimension of 2×2 cm². Afterward these strips are exposed to environment with a relative humidity of 75% at room temperature for 7 days. Moisture uptake is determined as percent weight gain of the strips (Gorle and Gattani, 2009).

$$\begin{aligned} \text{Percentage moisture uptake} &= \text{final weight} \\ &\quad - \text{initial weight}/\text{initial weight} \\ &\quad \times 100 \end{aligned}$$

5. Packaging of orally disintegrating films

Packing considerations are critical for storage, protection and stability of dosage form. Packaging for oral thin films includes foil paper or plastic pouches, single pouch, aluminum pouch, blister packaging with multiple units and barrier films. Barrier films are most commonly used for those drugs which

are extremely moisture sensitive (Patil et al., 2014). Rapid film technology developed by Labtec GmbH describes primary packaging made of a sealing pouch affords enough space for logos, codes, instructions or other information. The films are manufactured by a laminating process and packaging costs are comparable to tablets (Bhasin et al., 2011).

6. Conclusion

The present review shows that oral fast disintegrating films are one of the novel approaches in the field of pharmaceutical sciences. They have improved acceptance and patient compliance with no risk of choking associated with better safety and efficacy in comparison with conventional dosage forms. The main idea behind formulation of ODFs was to cope with the difficulty in swallowing conventional oral dosage forms among pediatric, geriatric and psychiatric patients with dysphagia. Presently, ODFs are widely available for hypertension, acidity, allergy, pain, etc. reflecting their importance. Major advantages of such dosage form are their administration without the use of water fulfilling the need of target population seeking convenience in drug administration along with bypassing the hepatic metabolism, consequently, leading to improved therapeutic response.

References

- Arya, A., Chandra, A., Sharma, V., Pathak, K., 2010. Fast dissolving oral films: an innovative drug delivery system and dosage form. *Int. J. Chem. Tech. Res.* 2, 576–583.
- Bai, G., Armenante, P.M., Plank, R.V., Gentzler, M., Ford, K., Harmon, P., 2007. Hydrodynamic investigation of USP dissolution test apparatus II. *J. Pharm. Sci.* 96, 2327–2349.
- Bala, R., Pawar, P., Khanna, S., Arora, S., 2013. Orally dissolving strips: A new approach to oral drug delivery system. *Int. J. Pharm. Investig.* 3, 67–73.
- Bansal, S., Bansal, M., Garg, G., 2013. Formulation and evaluation of fast dissolving film of an antihypertensive drug. *Int. J. Pharm. Chem. Bio. Sci.* 3, 1097–1108.
- Bhasin, R.K., Bhasin, N., Ghosh, P.K., 2011. Advances in formulation of orally disintegrating dosage forms: a review article. *Indo Global J. Pharm. Sci.* 1, 328–353.
- Bhyan, B., Jangra, S., Kaur, M., Singh, H., 2011. Orally fast dissolving films: innovations in formulation and technology. *Int. J. Pharm. Sci. Rev. Res.* 9, 9–15.
- Chaudhary, H., Gauri, S., Rathee, P., Kumar, V., 2013. Development and optimization of fast dissolving oro-dispersible films of granisetron HCl using Box-Behnken statistical design. *Bullet. Faculty Pharm.* 51, 193–201.
- Chauhan, I., Yasir, M., Nagar, P., 2012. Insights into polymers: film formers in mouth dissolving films. *Drug Invent. Today* 3, 56–73.
- Choudhary, D.R., Patel, V.A., Chhalotiya, U.K., Patel, H.V., Kundawala, A.J., 2012. Development and characterization of pharmacokinetic parameters of fast-dissolving films containing levocetirizine. *Sci. Pharm.* 80, 779–787.
- Cilurzo, F., Cupone, I.E., Minghetti, P., Selmin, F., Montanari, L., 2008. Fast dissolving films made of maltodextrins. *Eur. J. Pharm. Biopharm.* 70, 895–900.
- Cilurzo, F., Cupone, I.E., Minghetti, P., Buratti, S., Gennari, C.G., Montanari, 2011. Diclofenac fast-dissolving film: suppression of bitterness by a taste-sensing system. *Drug Dev. Ind. Pharm.* 37, 252–259.
- Desu, P.K., Brahmaiah, B., Nagalakshmi, A., Neelima, K., Nama, S., Baburao, C., 2013. An overview on rapid dissolving films. *Asian J. Pharm. Res.* 3, 15–23.
- Dinge, A., Nagarsenker, M., 2008. Formulation and evaluation of fast dissolving films for delivery of triclosan to the oral cavity. *AAPS Pharm. Sci. Tech.* 9, 349–356.
- Elmeshad1, A.N., Hagrasy, A.S.E., 2011. Characterization and optimization of orodispersible mosapride film formulation. *AAPS Pharm. Sci. Tech.* 12, 1384–1392.
- El-Setouhy, D.A., El-Malak, N.S.A., 2010. Formulation of novel tianeptine sodium orodispersible film. *AAPS Pharm. Sci. Tech.* 11, 1018–1025.
- Goel, H., Rai, P., Rana, V., Tiwary, A.K., 2008. Orally disintegrating systems: innovations in formulation and technology. *Recent Pat. Drug Delivery Formulation* 2, 258–274.
- Goel, A.P., Gattani, S.G., 2009. Design and evaluation of polymeric ocular drug delivery system. *Chem. Pharm. Bull.* 57, 914–919.
- Joshi, P., Patel, H., Patel, V., Panchal, R., 2012. Formulation development and evaluation of mouth dissolving film of domperidone. *J. Pharm. Bioallied Sci.* 108, 9–17.
- Juliano, C., Cossu, M., Pigozzi, P., Rasso, G., Giunchedi, P., 2008. Preparation, in vitro characterization and preliminary in vivo evaluation of buccal polymeric films containing chlorhexidine. *AAPS Pharm. Sci. Tech.* 9, 1153–1160.
- Kulkarni, A., Deokule, H., Mane, M., Ghadge, D., 2010. Exploration of different polymers for use in the formulation of oral fast dissolving strips. *J. Curr. Pharm. Res.* 2, 33–35.
- Liew, K.B., Tan, Y.T., Peh, K.K., 2012. Characterization of oral disintegrating film containing donepezil for alzheimer disease. *AAPS Pharm. Sci. Tech.* 13, 134–142.
- Mishra, R., Amin, A., 2011. Formulation and characterization of rapidly dissolving films of cetirizine hydrochloride using pullulan as a film forming agent. *Ind. J. Pharm. Edu. Res.* 45, 75–76.
- Murata, Y., Isobe, T., Kofuji, K., Nishida, N., Kamaguchi, R., 2010. Preparation of fast dissolving films for oral dosage from natural polysaccharides. *Materials* 3, 4291–4299.
- Nishimura, M., Matsuura, K., Tsukioka, T., Yamashita, H., Inagaki, N., Sugiyama, T., Itoh, Y., 2009. In vitro and in vivo characteristics of prochlorperazine oral disintegrating film. *Int. J. Pharm.* 368, 98–102.
- Panda, B.P., Dey, N.S., Rao, M.E.B., 2012. Development of innovative orally fast disintegrating film dosage forms: a review. *Int. J. Pharm. Sci. Nanotechnol.* 5, 1666–1674.
- Parejiya, P.B., Patel, R.C., Mehta, D.M., Shelat, P.K., Barot, B.S., 2012. Quick dissolving films of neбивол hydrochloride: formulation and optimization by a simplex lattice design. *J. Pharm. Investig.* 43, 343–351.
- Patel, R.S., Poddar, S.S., 2009. Development and characterization of mucoadhesive buccal patches of salbutamol sulphate. *Curr. Drug Deliv.* 6, 140–146.
- Pathare, Y.S., Hastak, V.S., Bajaj, A.N., 2013. Polymers used for fast disintegrating oral films: a review. *Int. J. Pharm. Sci. Rev. Res.* 21 (1), 169–178.
- Patil, P.C., Shrivastava, S.K., Vaidehi, S., Ashwini, P., 2014. Oral fast dissolving drug delivery system: a modern approach for patient compliance. *Int. J. Drug Regulat. Affairs* 2 (2), 49–60.
- Preis, M., Pein, M., Breitzkreutz, J., 2012. Development of a taste-masked orodispersible film containing dimenhydrinate. *Pharmaceutics* 4, 551–562.
- Raju, S., Reddy, P.S., Kumar, V.A., Deepthi, A., Reddy, K.S., Reddy, P.V.M., 2011. Flash release oral films of metoclopramide hydrochloride for pediatric use: formulation and in-vitro evaluation. *J. Chem. Pharm. Res.* 3, 636–646.
- Satyanarayana, D.A., Keshavarao, K.P., 2012. Fast disintegrating films containing anastrozole as a dosage form for dysphagia patients. *Arch. Pharmacol Res.* 35, 2171–2182.

- Siddiqui, M.N., Garg, G., Sharma, P.K., 2011. A short review on “A novel approach in oral fast dissolving drug delivery system and their patents”. *Adv. Biol. Res.* 5, 291–303.
- Sonawane, S.H., Thakare, V.P., Tekade, B.W., Patil, D.V.R., 2012. Formulation and evaluation of famotidine fast dissolving oral films. *World J. Pharm. Res.* 1, 1084–1095.
- Thakur, R.R., Rathore, D.S., Narwal, S., 2012. Orally disintegrating preparations: recent advancement in formulation and technology. *J. Drug Deliv. Therap.* 2 (3), 87–96.
- Yellanki, S.K., Jagtap, S., Masareddy, R., 2011. Dissofilm: a novel approach for delivery of phenobarbital; design and characterization. *J. Young Pharm.* 3, 181–188.