

MYO15A
c.4273C>T p.Gln1425X

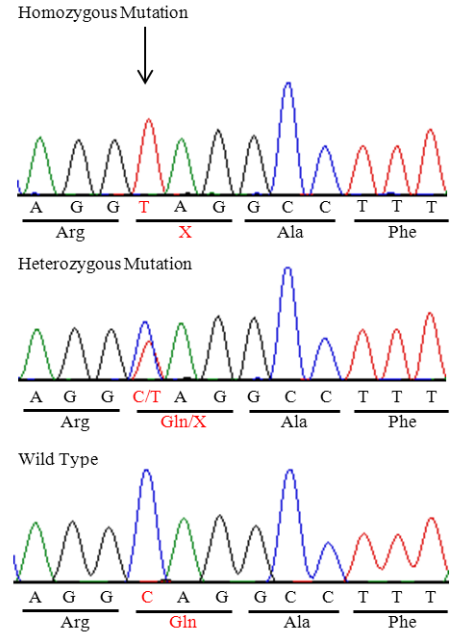

LOXHD1
c.2863G>T p.Glu955X

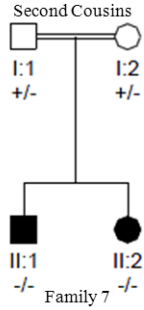
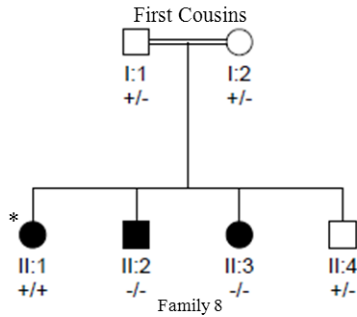

*This person has an inner ear anomaly not present in other affected persons.

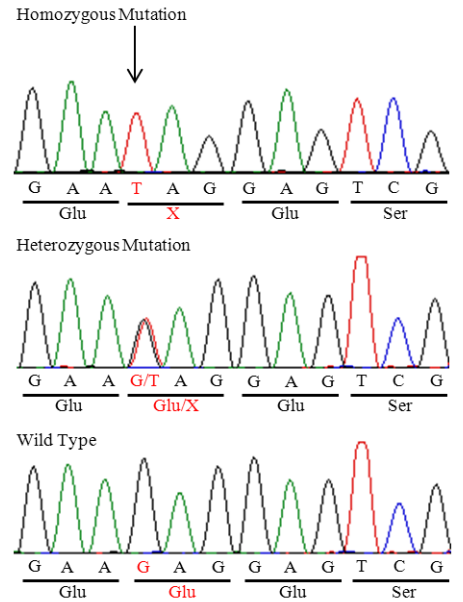

GIPC3
c.508C>A p.His170Asn

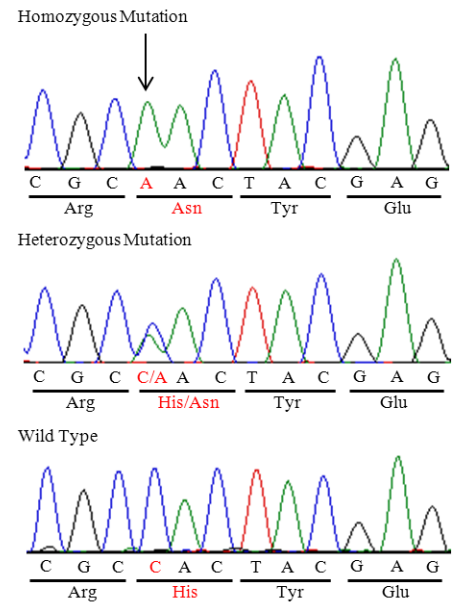
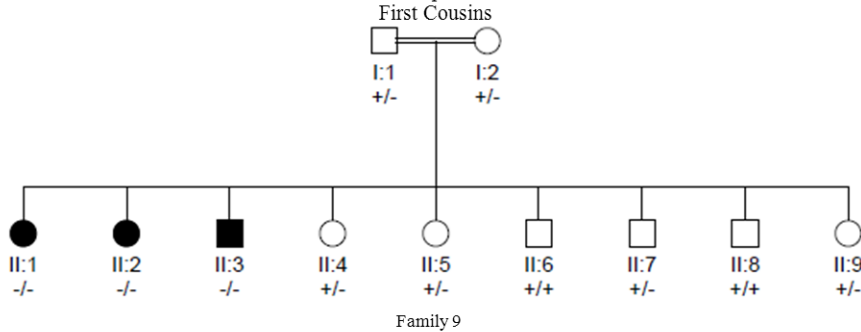

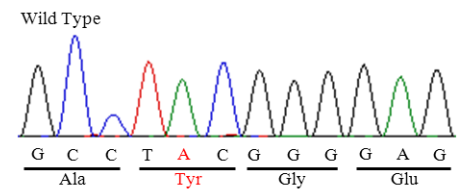
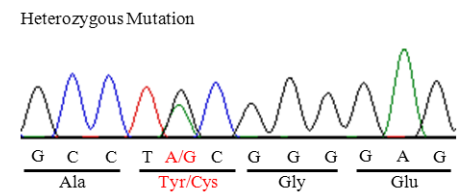
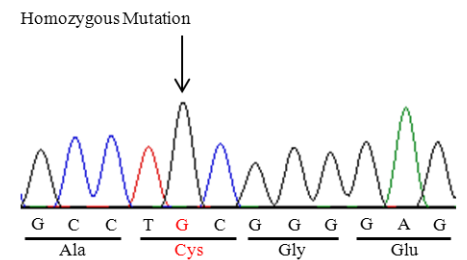
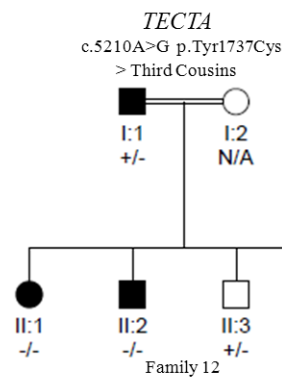
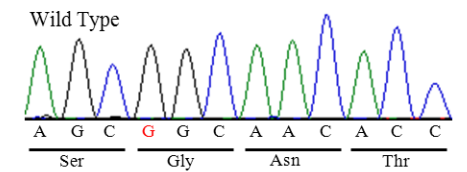
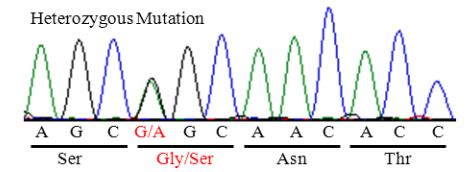
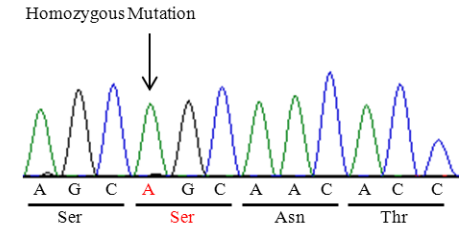
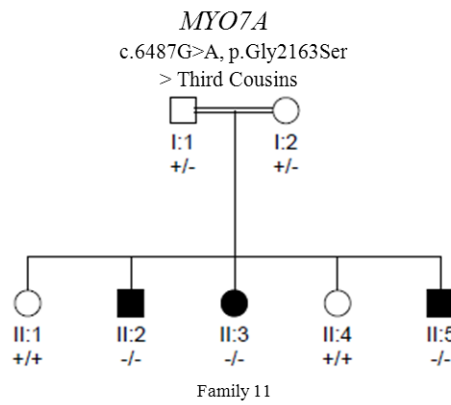
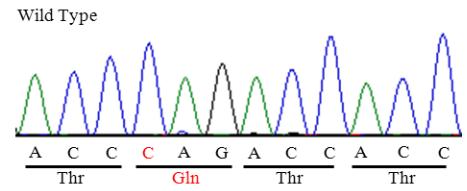
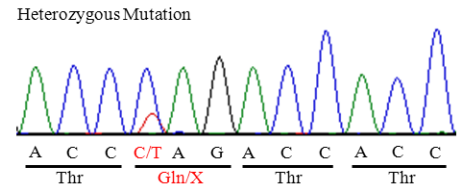
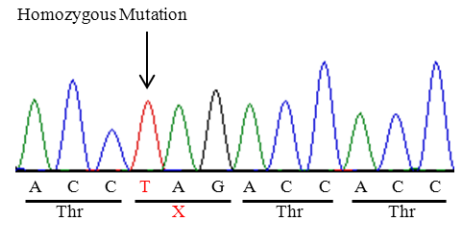
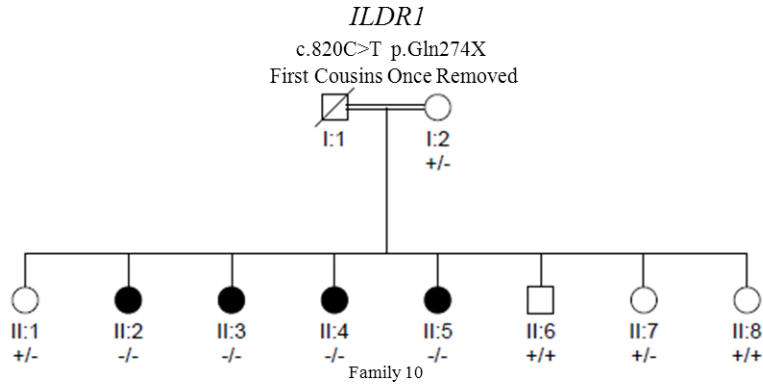

Article title: Whole-exome sequencing efficiently detects rare mutations in autosomal recessive nonsyndromic hearing loss

Journal name: Human Genetics

Author names: Oscar Diaz-Horta¹, Duygu Duman², Joseph Foster II¹, Aslı Sirmacı¹, Michael Gonzalez¹, Nejat Mahdieh³, Nikou Fotouhi⁴, Mortaza Bonyadi⁴, Filiz Başak Cengiz², Ibis Menendez¹, Rick H. Ulloa¹, Yvonne J.K. Edwards¹, Stephan Züchner¹, Susan Blanton¹, Mustafa Tekin¹

Affiliations:

1) John P. Hussman Institute for Human Genomics and the Dr. John T. Macdonald Department of Human Genetics, University of Miami Miller School of Medicine, Miami, USA

2) Division of Pediatric Genetics, Ankara University School of Medicine, Ankara, Turkey

3) Growth and Development Research Center, Tehran University of Medical Sciences, Tehran, Iran

4) Faculty of Natural Sciences, Center of Excellence for Biodiversity, University of Tabriz, Tabriz, Iran

Email address of the corresponding author: mtekin@med.miami.edu